













	Bei der Montage ist die Anleitung des Antriebs unbedingt zu berücksichtigen. Besonders die Sicherheitshinweise sind zu beachten!	D
	When mounting please observe by all means the installation instructions of the operator. Pay special attention to the safety advice!	GB
	Lors du montage, il faut absolument tenir compte des instructions concernant l'opérateur. Il est particulièrement important de respecter les consignes de sécurité!	F
	Bij de montage moet de montage- bedieningshandleiding van de aandrijving in acht worden genomen. In het bijzonder dienen de veiligheidsinstructies te worden opgevolgd!	NL
	Per i lavori di montaggio osservare sempre le istruzioni di montaggio fornite in dotazione con la motorizzazione. Osservare in particolare gli avvisi di sicurezza!	I
	Al realizar el montaje es estrictamente necesario tener en cuenta las instrucciones del operador. ¡Hay que observar especialmente las indicaciones de seguridad!	E
	Na montagem é indispensável considerar o manual do accionamento. Especialmente as indicações de segurança devem ser observadas!	P
	Vid monteringen skall anvisning för drivningen ovillkorligen beaktas. Speciellt säkerhetsanvisningarna skall beaktas!	S
	Det er tvingende nødvendig å følge bruksanvisningen for drivenheten under monteringen. Særlig sikkerhetsinstruksene må følges!	N
	A szereléskor feltétlenül tekintetbe kell venni a kapuműködtető útmutatóját. Különösen a biztonságtechnikai útmutatásokat kell követni!	H
	Pri montaži je potrebno brezpogojno upoštevati navodila pogona. Posebej se morajo upoštevati varnostna navodila!	SLO
	Při montáži bezpodmínečně dodržujte montážní návod pro pohon. Zvláště pak dodržujte bezpečnostní pokyny!	CZ
	Podczas montażu należy koniecznie przestrzegać instrukcji napędu, a w szczególności wskazówek bezpieczeństwa!	PL
	Montuodami būtina laikytis pavaros naudojimo vadovo. Ypatingai atkreipkite dėmesį į saugos nuorodas!	LT
	Во время проведения монтажа необходимо принимать во внимание положения руководства по работе привода. В особенности следует учитывать указания по технике безопасности!	RUS
	Ved montagen skal man ubetinget være opmærksom på vejledningen til drevet. Bemærk i særdeleshed sikkerhedshenvisninger!	DK

1.



2.

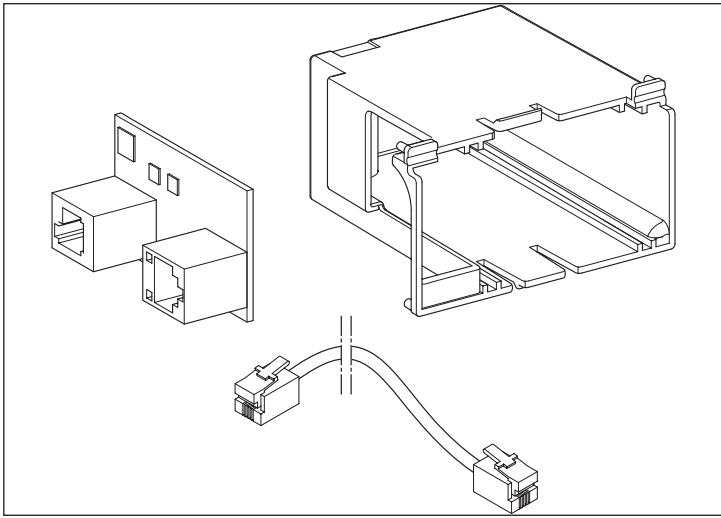
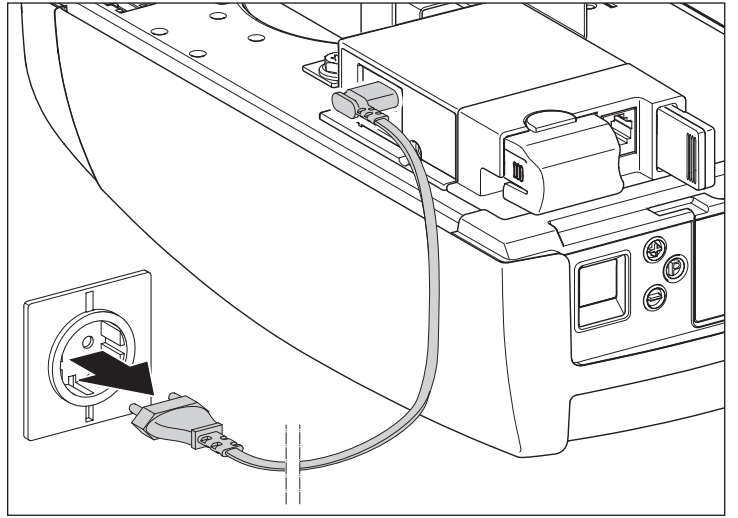

3.

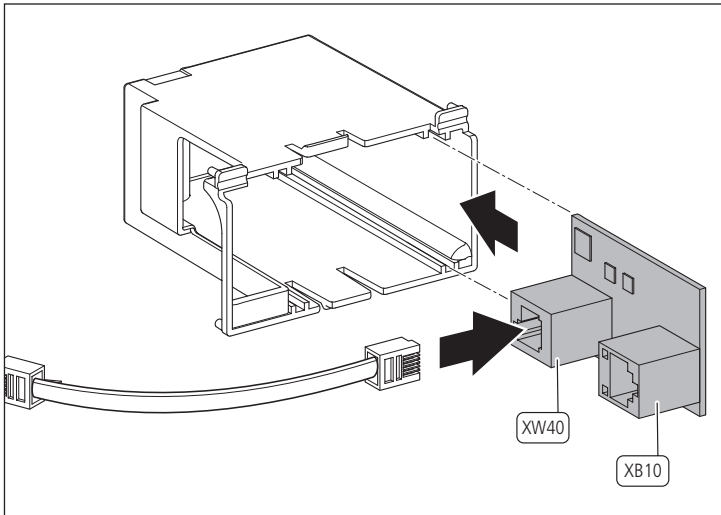

4.

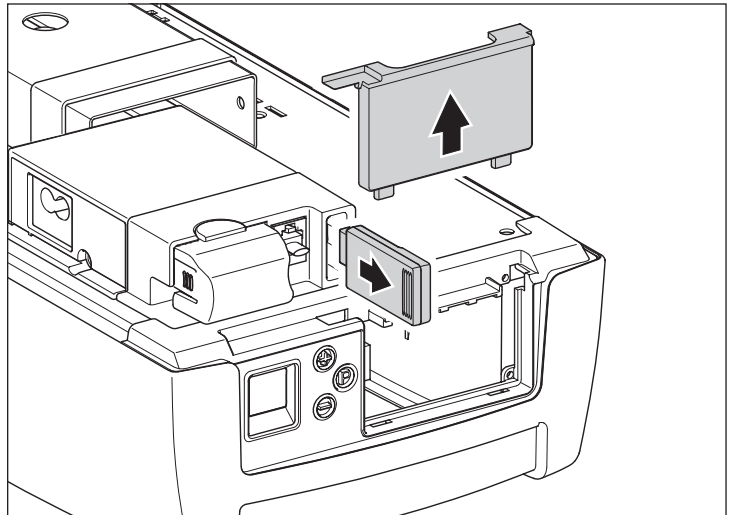

5.

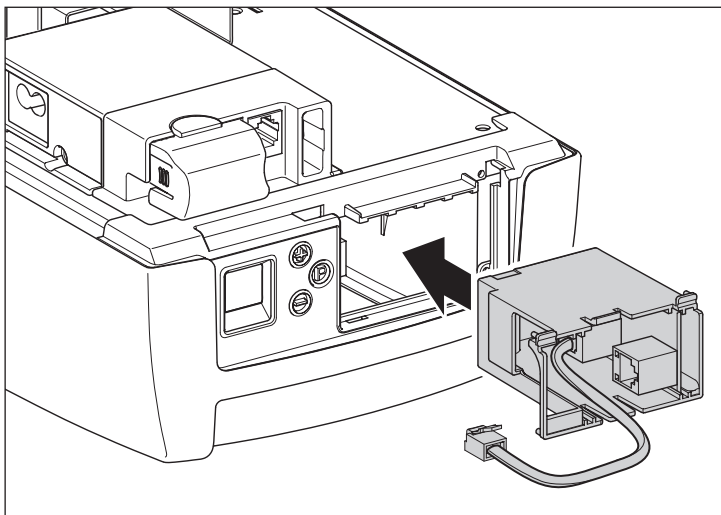

6.

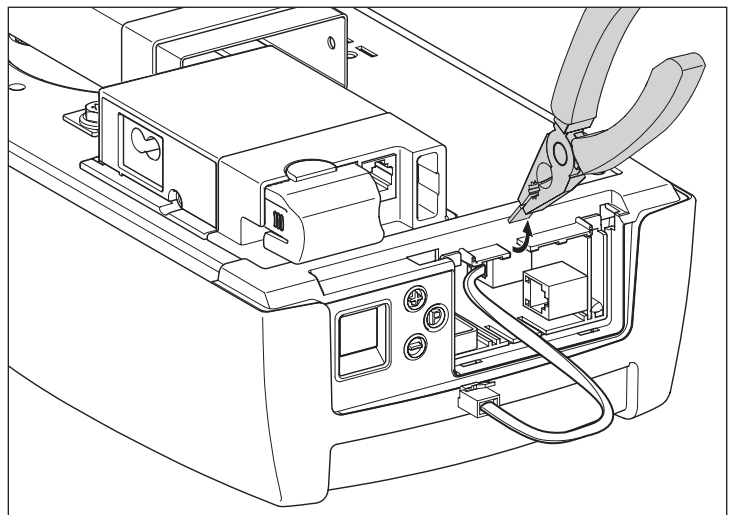

7.

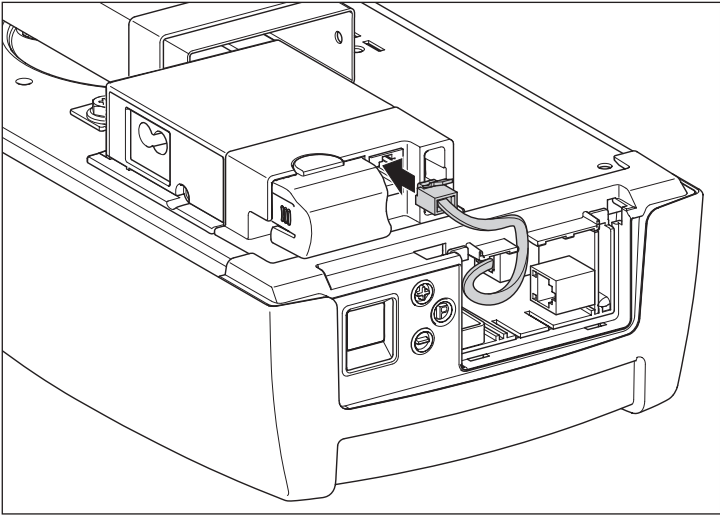

8.

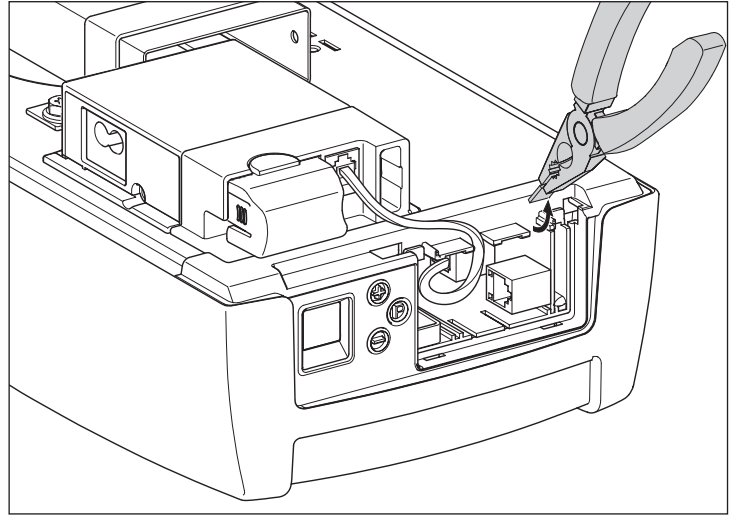

9.

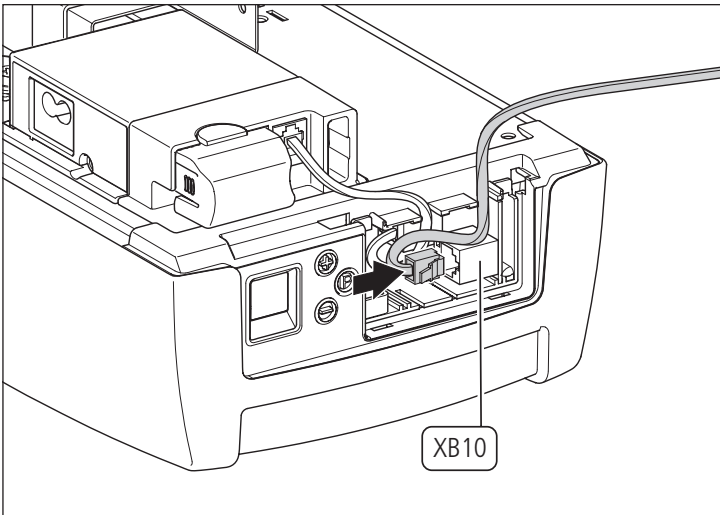

10.

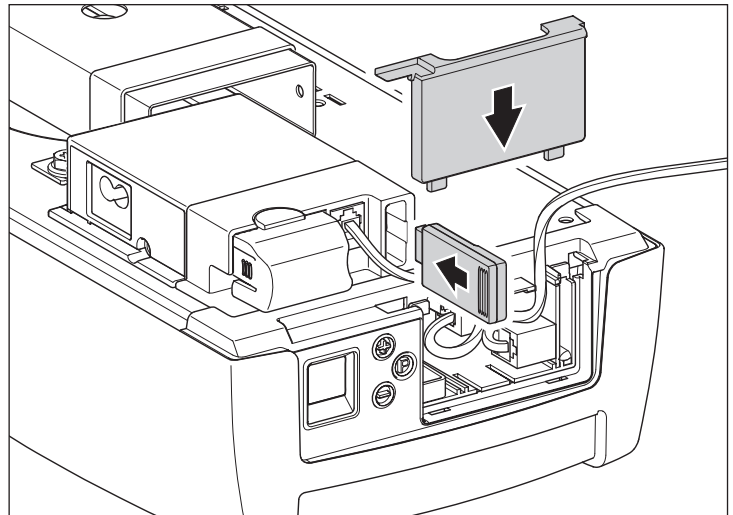

11.

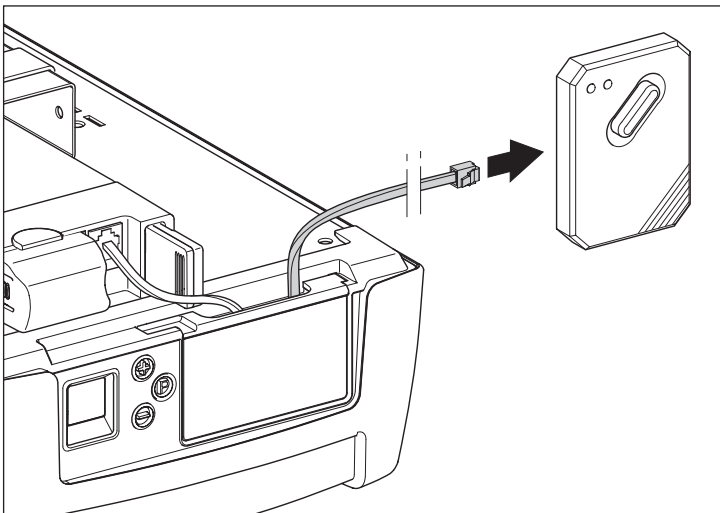

12.

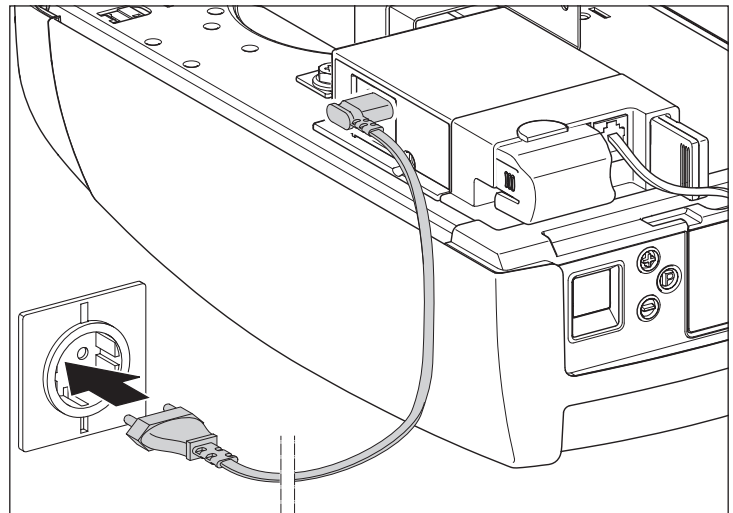

<b>Deutsch</b>	Originalanleitung, Urheberrechtlich geschützt. Nachdruck, auch auszugsweise, nur mit unserer Genehmigung. Änderungen, die dem technischen Fortschritt dienen, vorbehalten.	<b>Norsk</b>	Original anvisning. Beskyttet med opphavsrett. Gjentrykk, også i utdrag, er kun tillatt med godkjennelse fra oss. Med forbehold om endringer i rammen av den tekniske utvikling.
<b>English</b>	Original instructions, Copyright. No part of this manual may be reproduced without our prior consent. Subject to changes which are in the interest of technical improvements.	<b>Magyar</b>	Eredeti útmutató. A jelen anyagot szerzői jog védi. Kinyomtatni, akárcsak kivonatosan is, csak engedélyünkkel szabad. A műszaki haladás célját szolgáló módosítások jogát fenntartjuk.
<b>Français</b>	Notice d'origine. Protégé par droits d'auteur. Reproduction, même partielle, seulement après autorisation de notre part. Sous réserve de modifications servant au progrès technique.	<b>Slovenščina</b>	Originalna navodila. Zaščiten z avtorskim pravom. Ponatis, tudi v izvlečkih, je dovoljen le z našim dovoljenjem. Spremembe, ki služijo tehnični izboljšavi proizvoda, so pridržane.
<b>Nederlands</b>	Oorspronkelijke handleiding. Auteursrechtelijk beschermd. Nadruk, ook gedeeltelijk, uitsluitend met onze toestemming. Wijzigingen met het oog op de technische vooruitgang voorbehouden.	<b>Česky</b>	Originální návod. Chráněno autorskými právy. Dotisk, i jen částí, možný pouze s naším svolením. Změny, které slouží technickému pokroku, vyhrazeny.
<b>Italiano</b>	Istruzioni originali, tutti i diritti riservati. Riproduzione, anche parziale, solo previa nostra autorizzazione. La ditta si riserva la facoltà di apportare modifiche in base al progresso tecnologico.	<b>Polski</b>	Oryginalna instrukcja obsługi, Chroniona prawem autorskim. Przy wykonywaniu przedruku, także fragmentów, konieczne jest uzyskanie naszej zgody. Zastrzegamy sobie prawo do wprowadzenia zmian wynikających z postępu technicznego.
<b>Español</b>	Instrucciones originales, Propiedad intelectual. Reimpresión, aunque se trate sólo de extractos, sólo con nuestro permiso. Sujeto a modificaciones en función del progreso técnico.	<b>Русский</b>	Оригинальное руководство, Авторские права защищены. Перепечатка, даже выдержками, только с нашего разрешения. Мы оставляем за собой право на изменения, служащие техническому прогрессу.
<b>Português</b>	Instruções Originais. Protegido por direito autoral. Reprodução, inclusive parcial, somente com nossa autorização. Ressalvadas alterações que sirvam ao progresso técnico.	<b>Dansk</b>	Original anvisning. Ophavsretligt beskyttet. Genoptryk - også i uddrag - er kun tilladt med vores tilladelse. Ret til ændringer, som tjener teknisk fremskridt, forbeholdes.
<b>Svenska</b>	Originalanledning. Upphovsrättsskyddat. Eftertryck, även delvis, endast med vårt tillstånd. Med förbehåll för ändringar, som tjänar tekniska utvecklingen.		



100487